

The Aglass VT3000A Sewage Pump Station

UNIT COMES FULLY ASSEMBLED

600 MM
CAST IRON LIDS

GLANDS FOR
CABLES

LID OPTIONS:

600 MM ROUND
ALL LIDS ARE
GAS-TIGHT

CLASS B -
MEDIUM DUTY
CLASS D -
HEAVY DUTY
FIBREGLASS
LIDS FOR
ABOVE
BRASS EDGE
FOR TILING

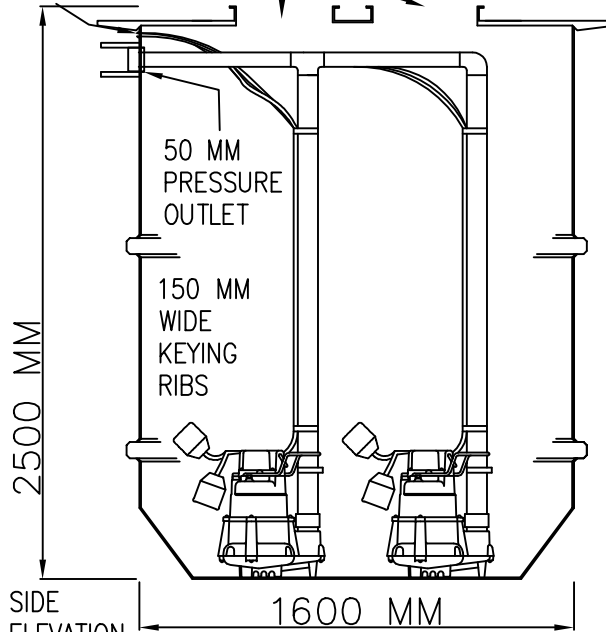

STANDARD FEATURES:

- 1x ALTERNATING CONTROL PANEL
- 1x HIGH LEVEL ALARM WITH FLASHING STROBE AND SIREN
- 2x SUBMERSIBLE SEWAGE SHREDDER CUTTER PUMPS (240/415 VOLTS)
- 2x ISOLATION TAPS
- 2x NON RETURN VALVES
- 2x LIFT CHAINS
- 2x PRESSURE UNIONS
- 2x PUMP AND PIPE BRACKETS
- 4x MAC3 BALL FLOAT SWITCHES

OPTIONAL EXTRAS:

- SLIDE RAIL KITS
- PIT RISERS
- ACCESS LADDER

2500 MM
SIDE
ELEVATION
(SECTION)

WORKING CAPACITY
4800L
MAXIMUM CAPACITY
5000L

AUSTRALIAN STANDARDS:

AS1170-P1
AS2634
AS1546

APPLICATIONS:

- RESIDENTIAL
- COMMERCIAL
- INDUSTRIAL
- SUBDIVISIONS

PLUMBER TO NOMINATE SIZE
AND QUANTITY OF INLETS

FOR PUMP OPTIONS INCLUDING
DIAGRAMS AND PERFORMANCE
CURVES
CONTACT AGLASS SALES

OTHER PUMP STATIONS ALSO AVAILABLE

THIS DOCUMENT IS CONFIDENTIAL THE COPYRIGHT THEREIN IS VESTED IN AGLASS SALES PTY LTD TAREN POINT, NSW, AUSTRALIA. RECIPIENTS MUST OBTAIN THE WRITTEN AUTHORITY OF THE SAID COMPANY BEFORE WHOLLY OR PARTLY DUPLICATING THE CONTENTS OR DISCLOSING SAME TO OTHERS. ALL RIGHTS RESERVED.

	SIGNATURE	DATE
DRAWN	M.P.	28.02.04
CHECKED	K.A.	28.02.04
APPR'D	K.A.	28.02.04
DRAWING NUMBER: AGL-VT500-A		
SCALE:	NTS	SHEET SIZE A4



AGLASS SALES PTY LTD

PH (02) 9526 2822
FAX (02) 9525 5085