

The Aglass AUS90 Under Sink Grease Arrestor Pump Station

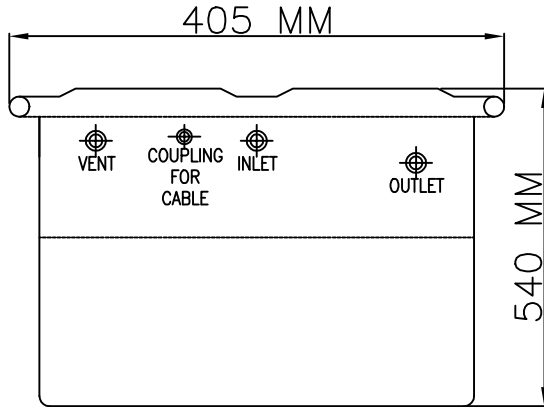

STANDARD FEATURES:

- 40 MM PRESSURE UNION
- 40 MM PRESSURE OUTLET
- 50 MM DWV INLET
- 50 MM DWV VENT
- SUBMERSIBLE VORTEX PUMP
- NON-RETURN VALVE
- ELECTRICAL CABLE GLAND

OPTIONAL EXTRAS:

- HIGH LEVEL ALARMS

APPLICATIONS:

- TAKEAWAY/HOT FOOD SHOPS
- BAKERIES
- SMALL RESTAURANTS ETC

TO BE USED WITH KITCHEN WASTE UP TO 1000 L/Hr

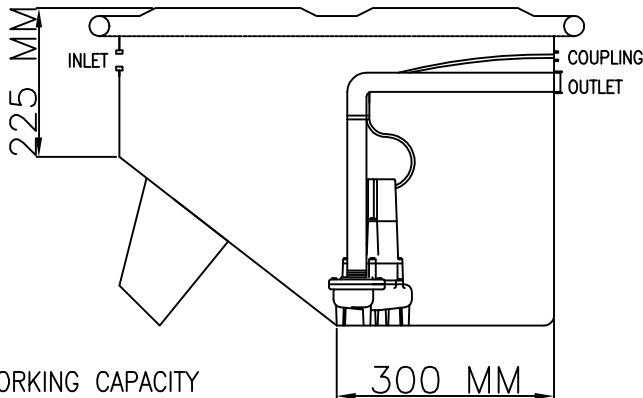

WORKING CAPACITY
85L
MAXIMUM CAPACITY
95L

AUSTRALIAN STANDARDS:

AS1170-P1
AS2634
AS1546

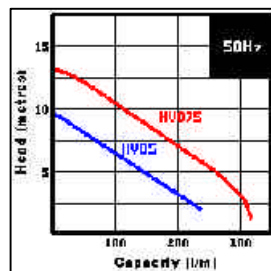

VORTEX PUMP
PERFORMANCE CURVES
HYFLOW SERIES PUMPS

OTHER PUMP STATIONS ALSO AVAILABLE

THIS DOCUMENT IS CONFIDENTIAL THE COPYRIGHT THEREIN IS VESTED IN AGLASS SALES PTY LTD TAREN POINT, NSW, AUSTRALIA. RECIPIENTS MUST OBTAIN THE WRITTEN AUTHORITY OF THE SAID COMPANY BEFORE WHOLLY OR PARTLY DUPLICATING THE CONTENTS OR DISCLOSING SAME TO OTHERS. ALL RIGHTS RESERVED.

	SIGNATURE	DATE
DRAWN	M.P.	28.02.04
CHECKED	K.A.	28.02.04
APPR'D	K.A.	28.02.04
DRAWING NUMBER: AGL-VT500-A		
SCALE:	NTS	SHEET SIZE A4



AGLASS SALES PTY LTD

PH (02) 9526 2822
FAX (02) 9525 5085